



**ЛЕШИЛА - МАЗИАКИ
ТОПЛОИЗОЛАЦИИ**

АЛМАНАХ

Откритията, които промениха света

**БЪЛГАРСКАТА
СЛЕДА В
СВЕТОВНАТА
АВИАЦИЯ**



**ЧИСТАТА
ЕНЕРГИЯ НА
БЪДЕЩЕТО**

*

**„АВС“ ИЛИ
ПЪРВИЯТ
КОМПЮТЪР**

**БЪЛГАРСКИЯТ
ИЗОБРЕТАТЕЛ
В СВЕТА НА
АВТОМОБИЛИТЕ**

*

**ОТКРИТИЕТО, ОТ
КОЕТО СЕ РОДИ
КСЕРОКСЪТ**



**БЪЛГАРИН Е ОТКРИВАТЕЛЯТ
НА НАЙ-ДАЛЕЧНАТА ПЛАНЕТА**



ЛЕПИЛА • МАЗИАКИ • ТОПЛОИЗОЛАЦИИ

2015

**СЕРИЯ „ВЕЧНИТЕ БЪЛГАРСКИ СИМВОЛИ“
ОТКРИТИЯТА, КОИТО ПРОМЕНИХА СВЕТА**

Скъпи колеги,
през изминалите 8 години имахме удоволствието да разкрием
пред Вас интересни факти и неподозирани тайни от
българското културно наследство. Всички те са повод не само
за възхищение, но и за гордост от това какво са оставили
дедите ни и какво сме съхранили за идните поколения.
Сега отваряме нова страница и с детско нетърпение бързаме да
представим пред Вас новото ни начинание, също толкова
неизчерпаемо и интригуващо, събиращо в себе си и история, и
предания, и човешки съдби...

Скъпи приятели,
запознайте се с новата кампания на „Теразид“ ЕООД, която ще
Ви провокира да научите повече за Великите постижения на
наши сънародници, за красотите на България и за минали
исторически събития.
Вярваме, че, също като нас, разгръщайки страниците на
„Вечните български символи“ и Вие ще бъдете покорени от
мащабите и величието на Българското. И забравяйки за
момент всекидневните грижи, ще съзрете онова голямо и
велико тайнство, което се крие във всеки от нас и което е повод
да се гордеем с миналото, а защо не и с бъдещето си?

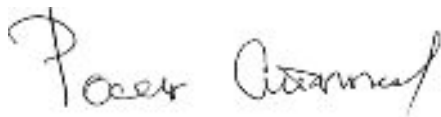

:

. 1..... -

. 3.....

. 7.....

. 9.....

. 11.....

. 15.....

. 17..... -

. 19.....

. 21..... ()

. 25.....

. 29.....

. 31.....

. 35.....

(1878, .



1878 .

(1905).

1905 . -

1907 .

„Lactobacillus delbureckii subsp. bulgaricus Grigoroff 1905“.



- 1945,)

36

1 000

- 4

1906



“ ”

” ”

” “ (.) .

” “ ”

The image shows the cover of the journal 'Presse Medicale'. At the top, the title 'PRESSE MEDICALE' is prominently displayed. Below the title, there is a list of names and titles, including 'P. AZAR' and 'M. GAZDAR'. On the left side, there is a circular portrait of a man with a mustache, wearing a suit and tie. The text on the cover is in French and includes the word 'REVUE' and 'PARIS' at the bottom.

1935

” “

(1896,

- 1967,

)



2
1896 .



18-

” “ -1“ 15 1915 .

Who.

Who's

” “ 50 , 65 85 / , 500 .

16- ” “

XX .

” “ ()

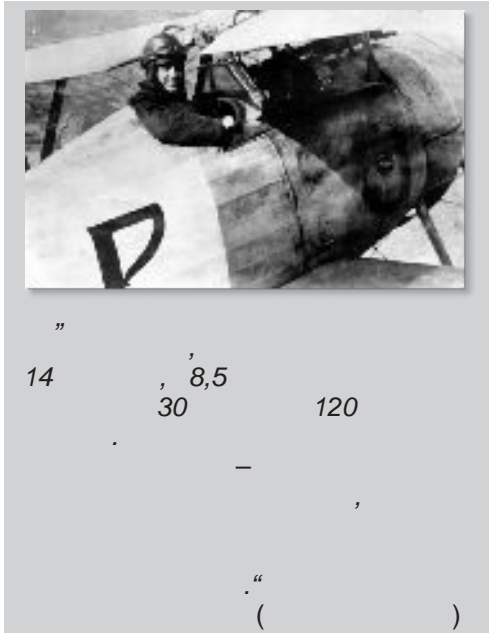

14 , 8,5 30 120

84

DC-3/C-47

1921

B-29

6000

(1932),

750 000.

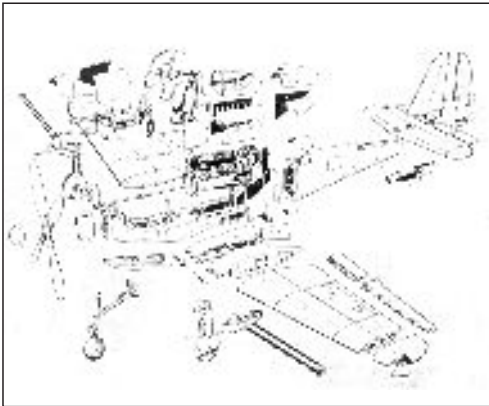

1941

The Jordanoff Aviation Corporation,
1946 – Jordanoff Electronics.

Fuller Building
Avenue E.57th Street

Madison

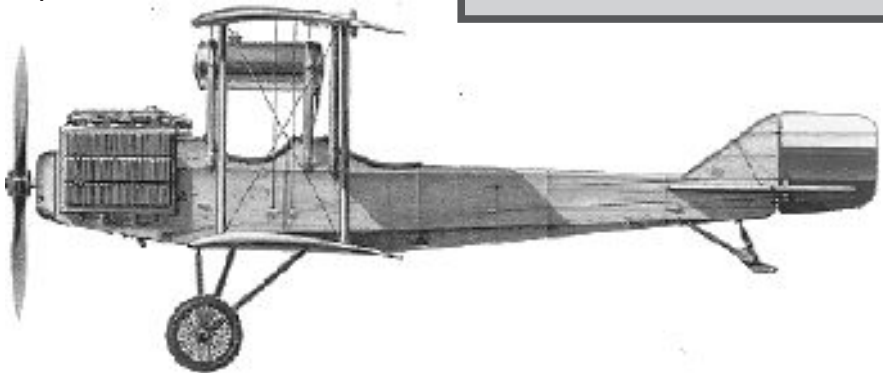
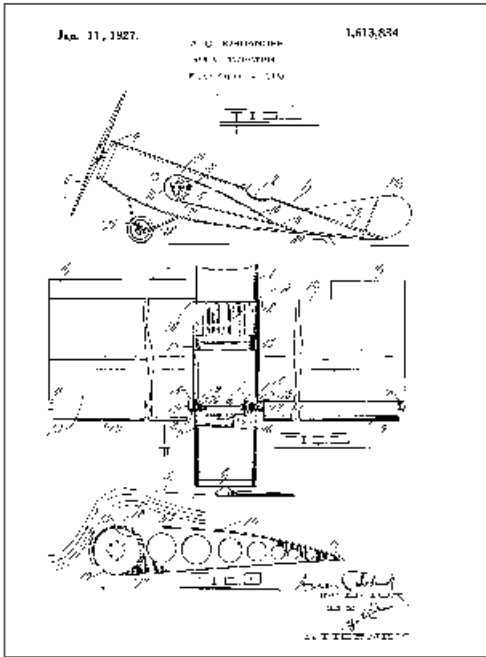

(Airbag)

Gasoline System),

(Frozen

(Reverse Thrust Device),



(Jordaphone) –

(The Stratoport)

” “
” “

“ 5
30



(1897, – 1981,)



(1937 .)

50-

1897

1920





”

1937

(

“

(1897, – 1979,)

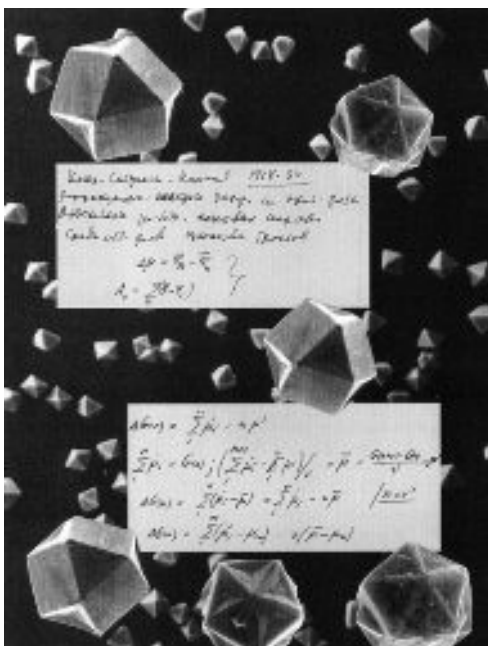

FEM.
40%



(1903, , – 1996, ,)



1939

4

1903 .

(1925),

(1926),

(1930).

(1939-1942),
(tanasoff – Berry – Computer).

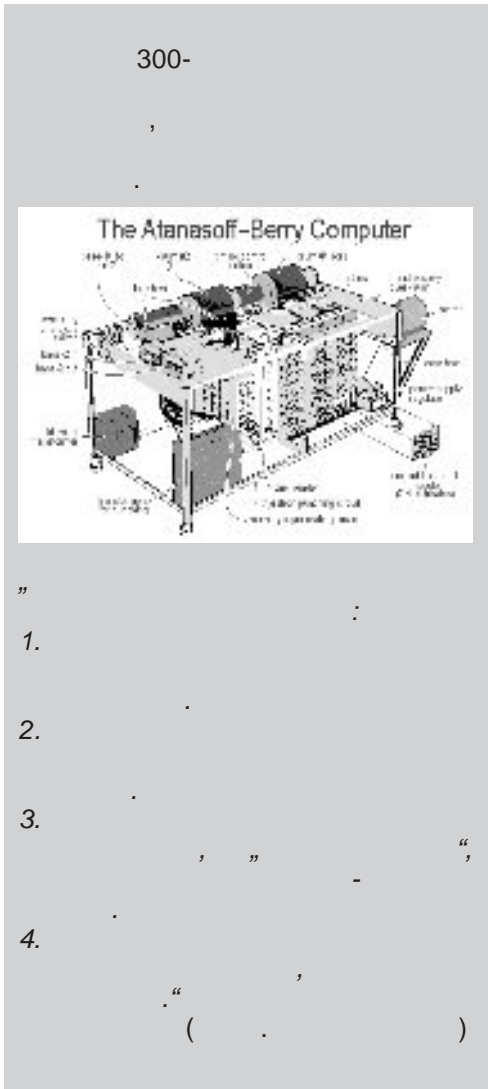

300-

The Atanasoff-Berry Computer

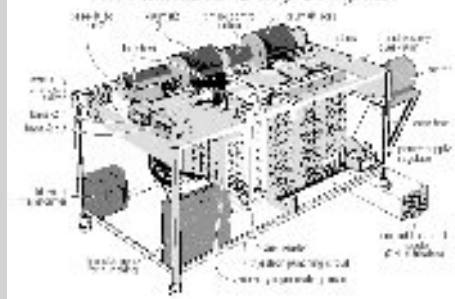

”

1.

2.

3.

4.

” ” “ ’

“ (.)



20 667

248

60

17

ENIAC

-

19

1983



ENIAC,

60 Hz

100 HZ

ENIAC,

(Burks, A.W., A.R. Burks)

ENIAC,

1967



ENIAC

ENIAC

77

7

1945 .

32

36 000

NBC - Data and Signal Flow Diagram

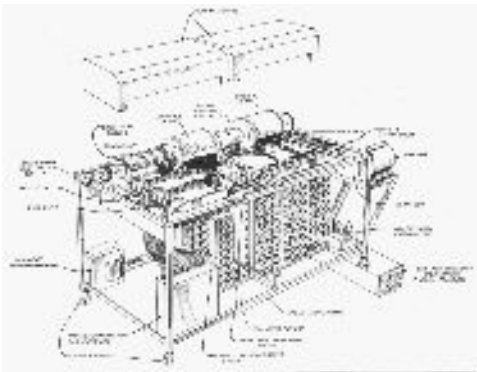
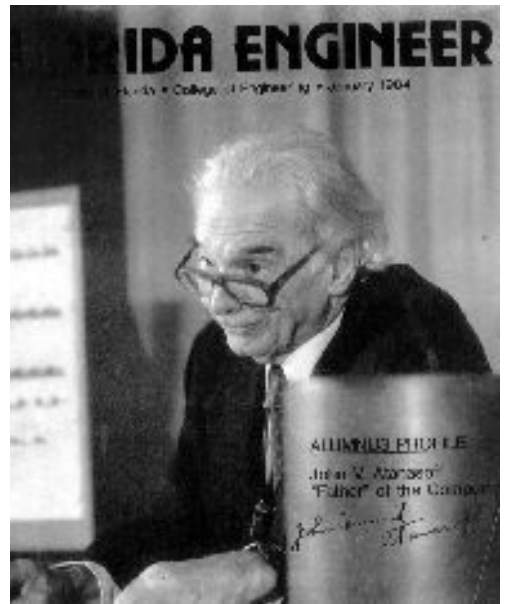
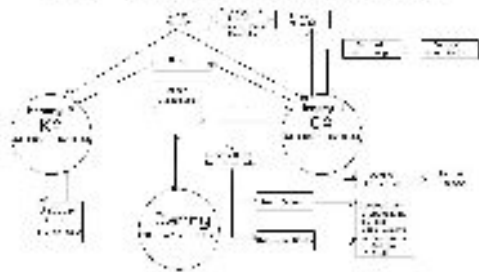

(1910, – 1997,)



100

1910

(1934).

(1988).

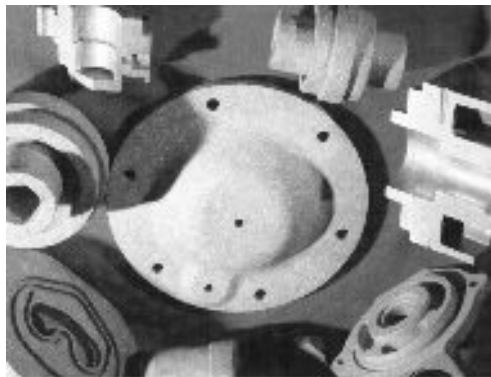

”

(1929 .),

’

—

“

’

’

’

’

’

’

’

’

’

’

’

’

’

’

’

’

’

’

’

’

’

’

’

’

’

’

’

’

’

’

’

’

’

’

’

’

’

’

’

’

’

’

’

’

’

’

’

” (800 000

),

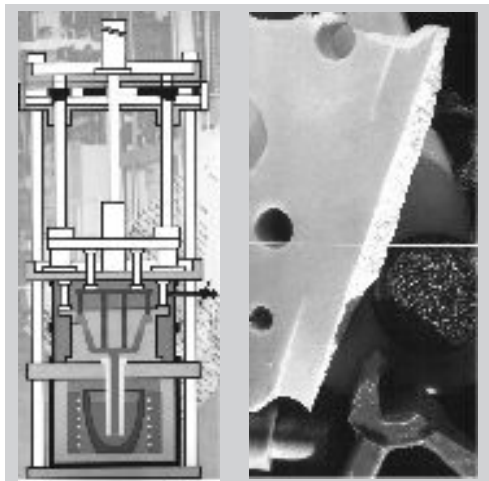

„American Eagle Wheel Corporation“

1998 .

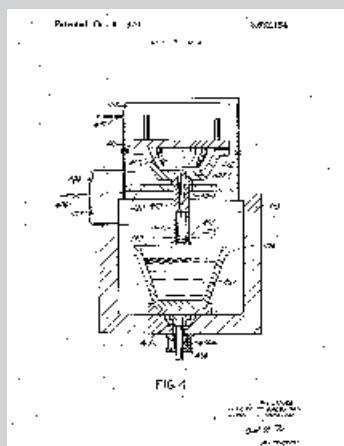

(1914 . . .

/

/ – 1986,

)

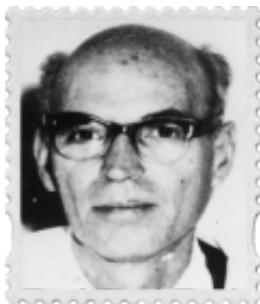

?

1956 . . .

(Nivalin®)

18
1914 . . .

1959 . . .

1961 . . .



1977 . . .

1959 . . .



Опаковка от първото производство Нивалин – ампули.



Д. Паскал Нивалин. Фармакология и специални приложения. София, 1986 г. ИБ „Док. за. Карел и Методи“



120

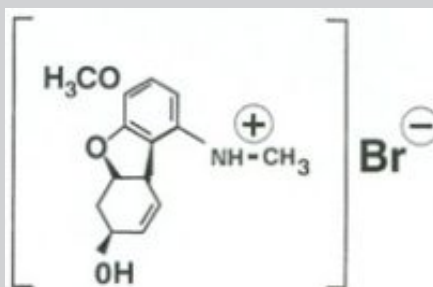

(1919,) – 2003,)



1919

1956

1939

1959

1963

1941



1944

1967

1951

60

BBC

1968

Electrics“

„Care

XX



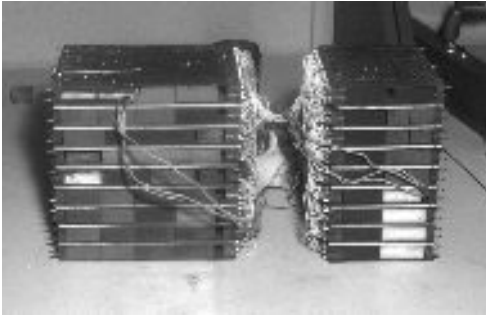

1975 .

– „ADS Environmental Services“,

13 .

50 . 55

12 .



26 .

4 .

7 .



1969 .

1971 . 2100

5 .

()

(1922, - 1998,)

80-

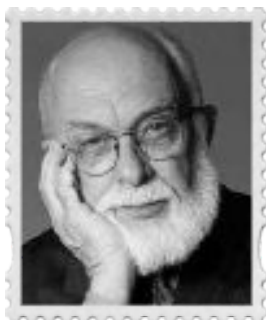

()

6000°

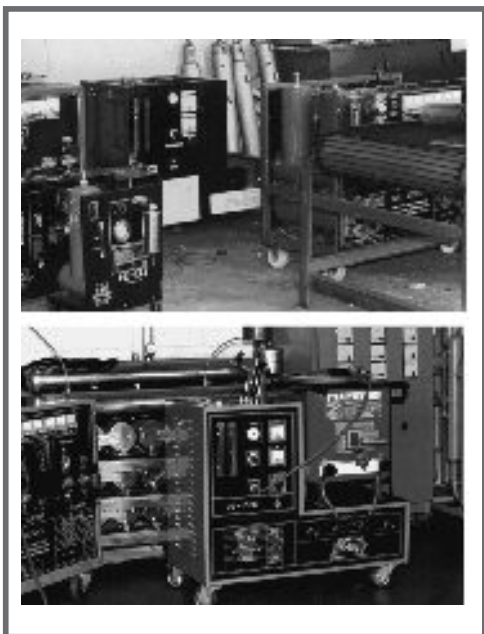

e
e
6000° - e e -
e !
e
e
e, e e
e e e
e e

16 1922 .

1948 .

1950 ., 1952 .

1956 .

1970 .

20 .

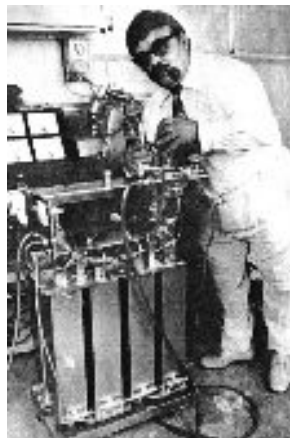

(

1972 .

5

1977 1978 .

1981 .

„Brown Energy“

1984 .,





EMERSON LABORATORY

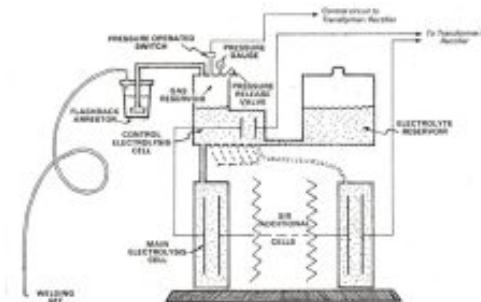

14

1992

1998

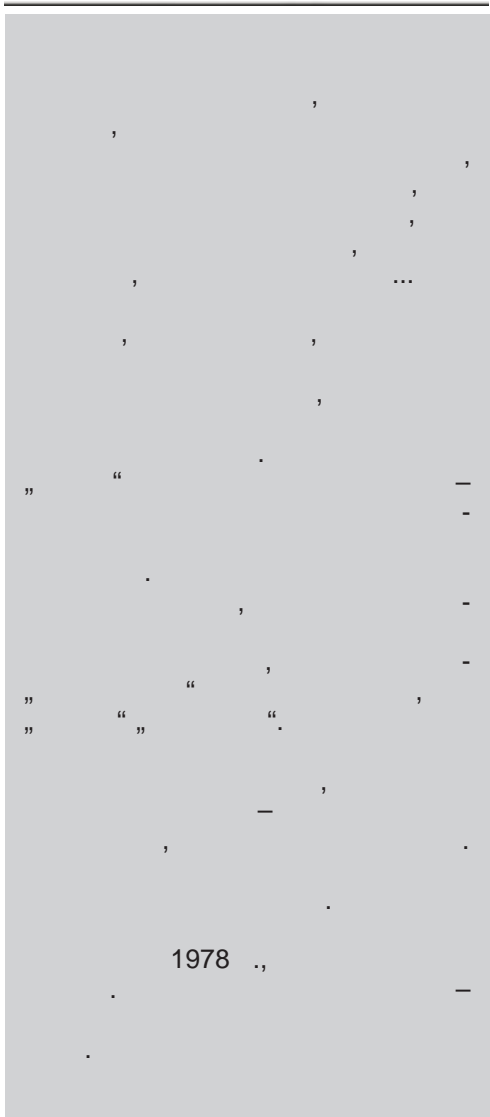

2:1.

2

e e , e e e

1600
2

4

1978

(1923,)

60

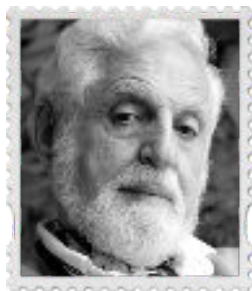

30-

birth-control pill
()

the Pill

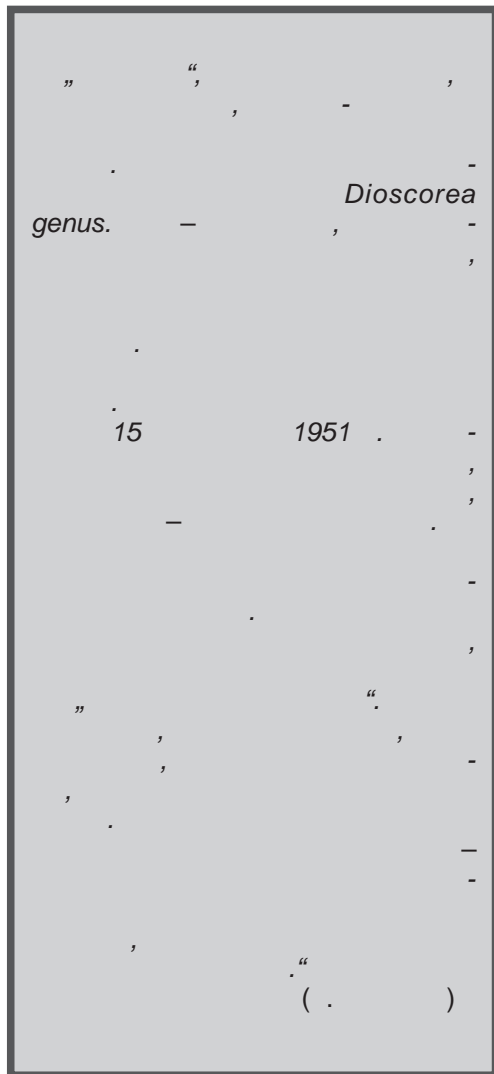

genus. *Dioscorea*

15

1951

(.)

Ciba
Pharmaceutical Co

Pyribenzamine.
28-



1936 .

(1959 .).

1200

16

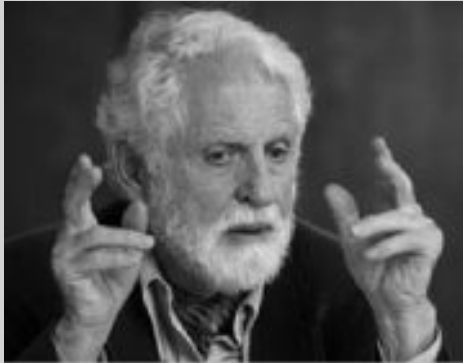

Syntex (1949),

Syntex

Zoecon,

Occidental

Petroleum.

” , , 60
theatre“.
2000 .

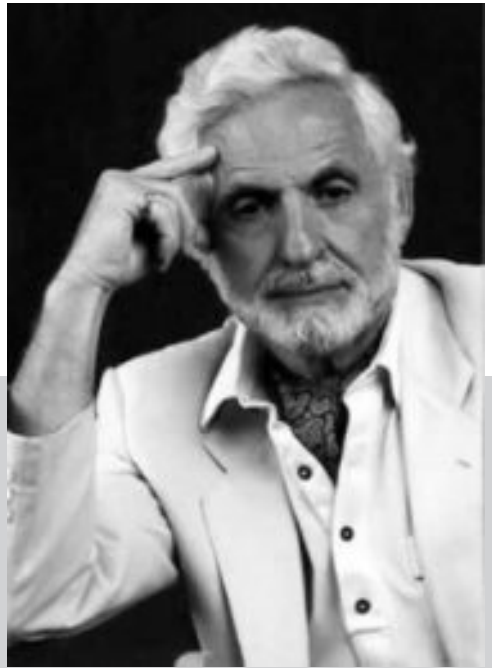

-
?
-
(
- ” “)

(1943, . , .)



-
,
-
,
-
- 2000 . - 1992 -
-
,
.

10-



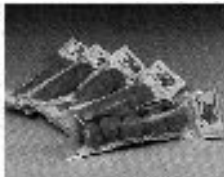

„Bulgarian Symbols“

„Bulgarian Symbols“



„Bulgarian Symbols“

„Bulgarian Symbols“

,
,
-
5

3000-3200

,
,
“

”

“

,
12 20

20

,
,

,
-

-
-

2 5%.
1/5 1/10

, 30
3 ”
“
(
),
,

(1944,)



100%



17
1988 .

25



1988 .

(
1992 .

),

(
) ,

“ (1976).

1977 .

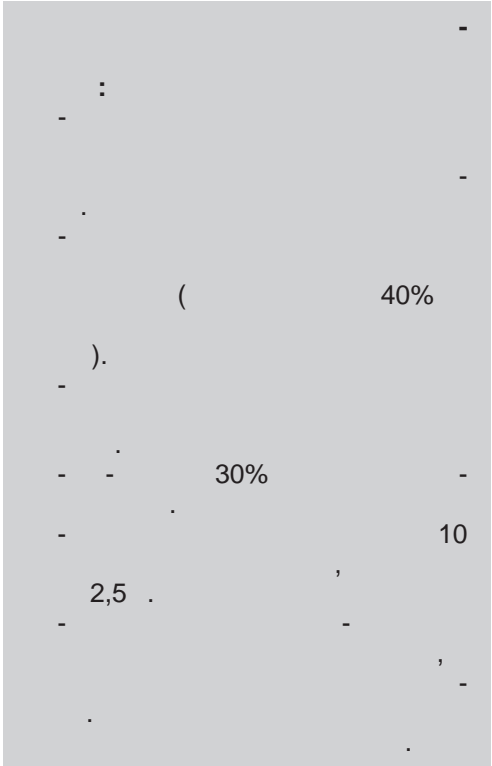
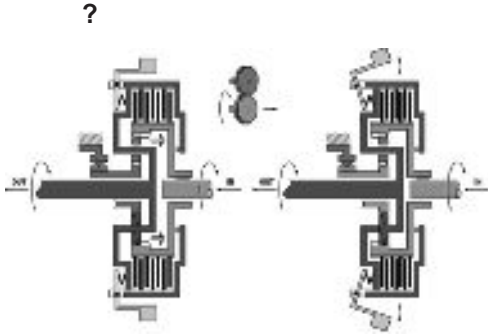

Anton v PLC –

1991 .



(,, “ ” “), (,, “ ”), (,, “ ”),
 (,, “ ”), (,, “ ”),
 ,, “ ”,
Antonov Automotive Technologies Group –
 1991 .,



„BMW“ „

30-40%

15-30%.

4 Stroke –

(2002).

4-

„4 Stroke (4)

Rumen“
1977 .

30-

100

400

General Characteristics :

ABS, EPS, Air Condition, Leather Interior, Fibre Composite Body
Engine :

Type :..... Central Rear, Gasoline

Capacity (cc) :..... 968

Cylinders :..... 3

Bore / Stroke (mm) :..... 71 x 04

Numbers of the Valves :..... 12

Maximum Power hp (kw) :... 60 (50) to 6000 (tuned version - 100 hp)

Maximum Torque Nm / lrm :... 93 to 3600

Ignition :..... EFI INJECT PORT

Transmission :

Type :..... 5 speed, 21tooth, manual/automatic

Chassis "Tubular" :

Brakes :..... Disc / Disc

Front suspension :..... Double triangle

Rear suspension :..... forged arm with
collapsible crossmember

Tyres :

Front :..... 165 / 60 R15

Rear :..... 185 / 60 R15

Dimensions :

Wheel Base :..... 2490

Front / Rear (mm) :..... 1420 / 1420

Length / Width / Height (mm) :... 3580 / 1600 / 1310

Luggage Volume (l) :..... 200

Fuel Tank (l) :..... 40

Weight :..... 550kg



(1961,)



1961



1998



2003

TR-56b.

5000

Ogle-

100

60



Origins of

Life Initiative,

100

60

(. .)

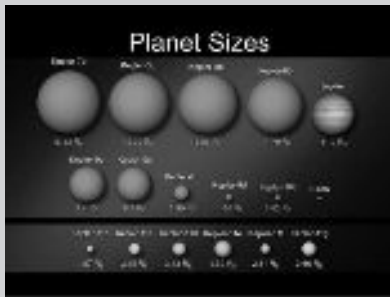

Kepler-10c,
2,3

29 000

560

45

Kepler-10c

3

Предпечат и печат: „Фреш Принт“ ООД

© Всички права запазени.

Материалите за кампанията „Откритията, които промениха света“
са реализирани с любезното съдействие
на Националния политехнически музей.

WWW.POLYTECHNICMUSEUM.ORG



www.terazid.com